



This drawing includes confidential information which is the property of ASHCROFT INC. This copy is loaned for a specific purpose, with the understanding that it will not be reproduced or used for any other purpose or disclosed to others, and it will be returned on demand.

NOTE 1: PANEL CUTOUT- $\varnothing 4.94$ [125] +/- 1/32 [1]

NOTE 2: PANEL THICKNESS- 1/16 [2] TO 1/4 [6]

NOTE 3: BRACKET POSITIONED FOR 1/4" PANEL

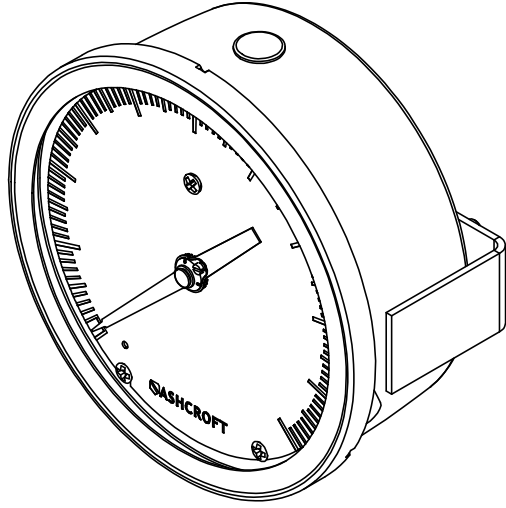
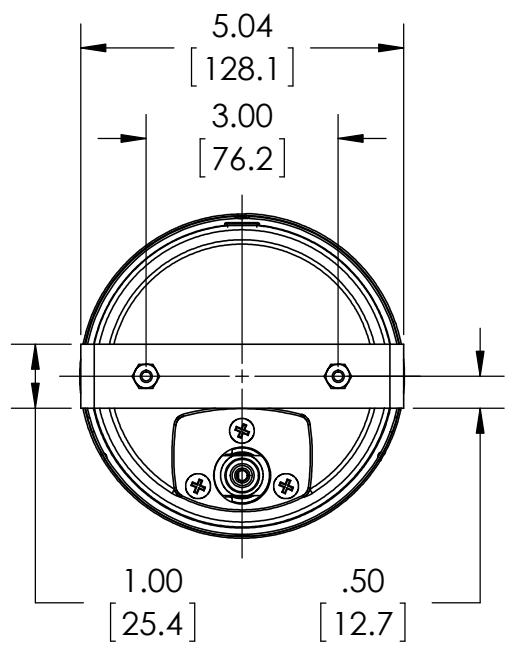
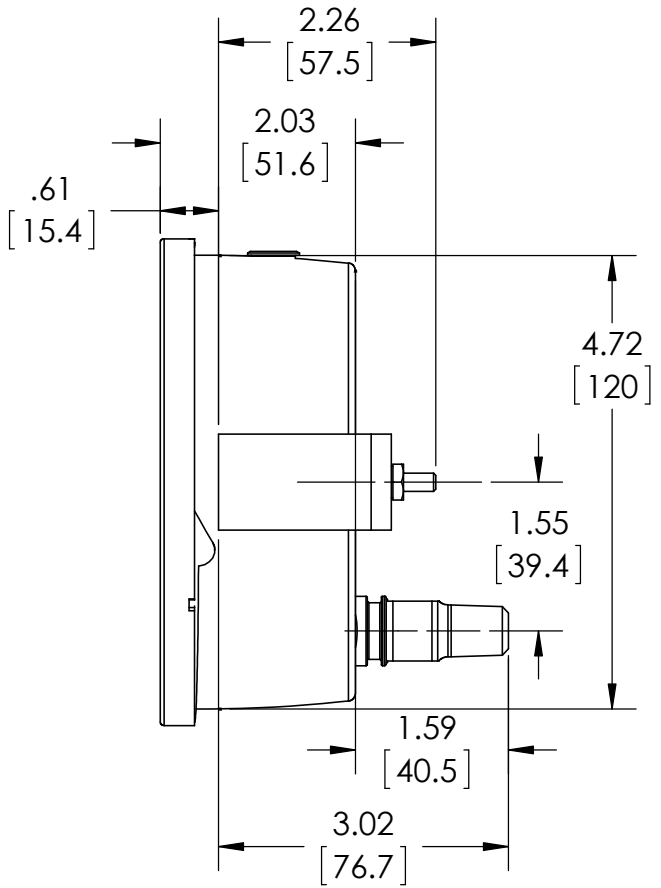
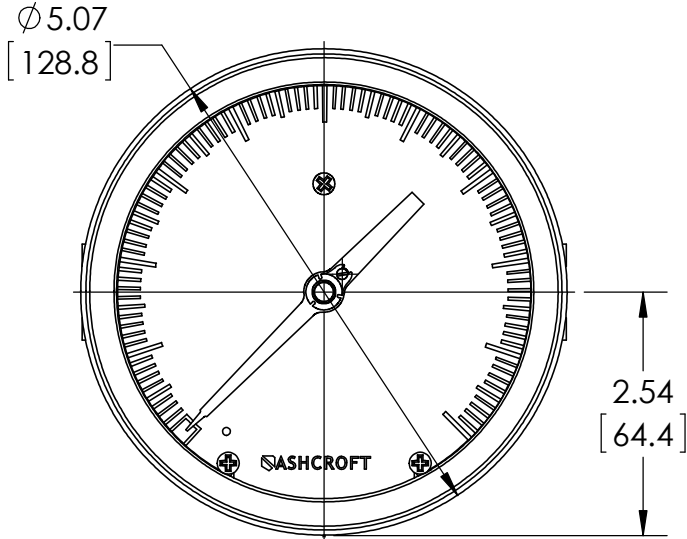

DIMENSIONS IN [] ARE MILLIMETERS

REV.	ECO	DESCRIPTION	BY	DATE
A	0004508	RELEASED GENERAL DIMS.	MJS	6/20/2011

This print certified correct for		General Dimensions		
Customer's Name		45 1009 02B XUC SERIES		
Customer's Order No.	Drawn MJS	Date 6/20/11	Date of Issue	
Ashcroft Order No.	Checked	Date	SHEET-1	Rev.
Certified by	Date	Approved	Date	70A3500
				A